

DRAIN TYPE D5
ALL PIPES

More than 900 cover

DRAIN TYPE D6
CONCRETE, CLAY
AND PLASTIC

Less than 900 cover





DRAIN TYPE D7
CONCRETE, CLAY
AND PLASTIC

Less than 900 cover
Concrete slab alternative
to concrete surround

DRAIN TYPE D8

Filter drain

Key:

-  Topsoil
-  Class 8 material to MCHW CL503-3(iv)
-  Granular pipe bedding to MCHW CL503-3(i)
-  Type B filter material to surface, to MCHW CL505
-  GEN1 Mix B or C bedding and surround - See note 11.
- Geotextile membrane
- Ground level

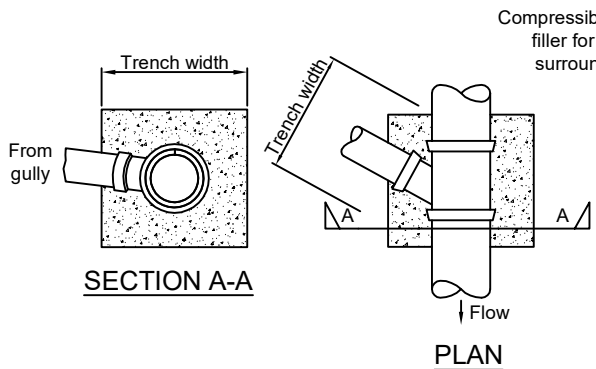

GULLY CONNECTION DETAILS

FLEXIBLE JOINT FOR CONCRETE
SURROUND
(REINFORCED SLAB SIMILAR)

Notes:

1. All dimensions are in millimetres unless shown otherwise.
2. C25/30 strength mix reinforcement and slab detail to be designed by Engineer
3. Pipe and bedding and materials must not be changed between chambers.
4. Saddle connections may only be used with the approval of the Engineer.
5. Slotted pipes to be laid with slots downwards unless otherwise directed.
6. Filter drain trenches may only be covered by topsoil where approved by the Engineer.
7. If more than one pipe connects to a drain, it will be 225mm diameter.
8. Pipes of 900mm diameter (D) or greater must comply with the requirements of DMRB CG300 Technical approval schedule for structures V.1.9.0 Jan.22.
9. Acceptable pipe materials shall be:
 - a) Vitrified clay pipes to BS65
 - b) Concrete Pipes to BS EN 1916
 - c) Thermoplastic pipes to MCHW Clause 518 (minimum SDR34)
10. For further information refer to Standard Details Guidance Note drawing no. HSD/100/001
11. For concrete specifications and mix information refer to the Concrete For Ancillary Purposes Standard Specification drawing no. HSD/100/002.

Table 1

Pipe diameter	Thickness of compressible board or joint filler
less than 450	18
450 - 1200	36
over 1200	54



DRAWING TITLE:
Series 500: Drainage and Service Ducts: Sewers and Drains -
Under Verges

SCALE: NTS

	DRAWN	CHECKED
INITIALS:	CS	MS
DATE:	12/01/2024	12/01/2024

REV	AMENDMENTS	DRN	CHCK'D	DATE

DRAWING NO:
HSD/500/005